

Name: _____ Date: _____ Event: _____ Track: _____

Track Conditions

<input type="checkbox"/> Indoor	<input type="checkbox"/> Tight	<input type="checkbox"/> Smooth	<input type="checkbox"/> Hard Packed	<input type="checkbox"/> Blue Groove	<input type="checkbox"/> Wet	<input type="checkbox"/> Low Bite	<input type="checkbox"/> High Bite
<input type="checkbox"/> Outdoor	<input type="checkbox"/> Open	<input type="checkbox"/> Rough	<input type="checkbox"/> Loose/Loamy	<input type="checkbox"/> Dry	<input type="checkbox"/> Dusty	<input type="checkbox"/> Med Bite	<input type="checkbox"/> Other

Front Suspension

Ride Ht	
Camber	
Toe	
Sway Bar	
Notes:	

- 0mm
- 1mm
- 2mm

- 0mm
- 1mm
- 2mm

- PI AI CVA
- 17.5 20 Universal

- 1mm
- 2mm

- STD
- +1mm

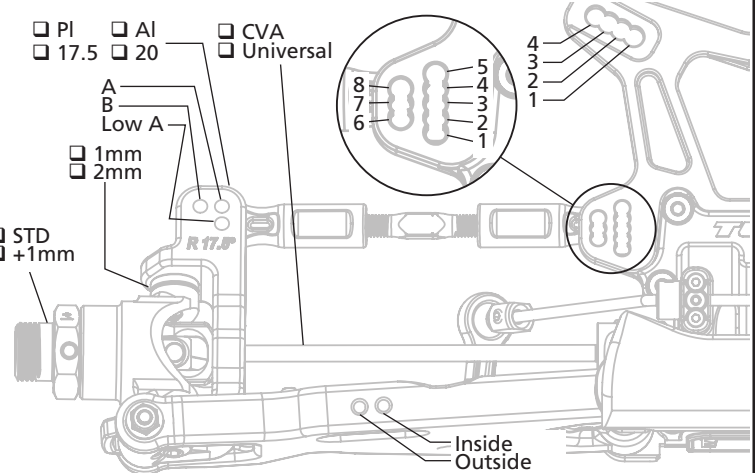
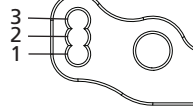
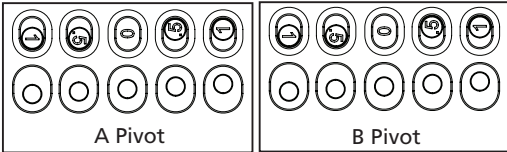

Rear Suspension

Ride Ht	
Camber	
Sway Bar	
Notes:	

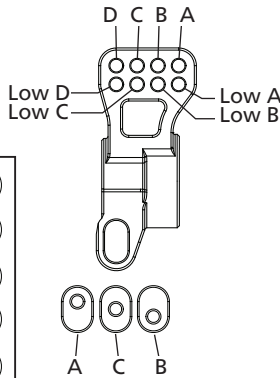
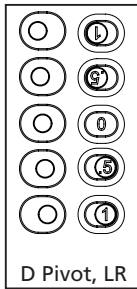

- CVA UNI DCVA
- 3 2 1

- STD
- +1mm
- +2mm

- A
- B

- STD
- LRC

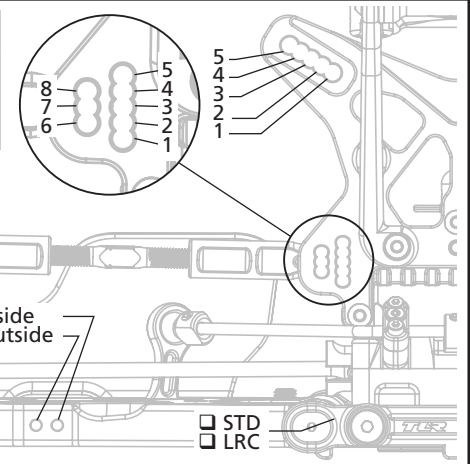

Chassis

Differentials	Front	Center	Rear
Fluid			
Pins	<input type="checkbox"/> AL <input type="checkbox"/> STL	<input type="checkbox"/> AL <input type="checkbox"/> STL	<input type="checkbox"/> AL <input type="checkbox"/> STL
Case	<input type="checkbox"/> STD <input type="checkbox"/> HD	<input type="checkbox"/> STD <input type="checkbox"/> HD	<input type="checkbox"/> STD <input type="checkbox"/> HD

Wing	
Brand	
<input type="checkbox"/> Riser	
<input type="checkbox"/> Wicker Bill	
<input type="checkbox"/> FWD <input type="checkbox"/> Back	

Engine and Clutch			
Engine		Fuel	
Glow Plug		Head Clearance	
Pipe/Header		Gearing	
Clutch Shoes		Clutch Springs	
Th Servo		St Servo	
Rx Pack		Flywheel	<input type="checkbox"/> AL <input type="checkbox"/> STL

Shocks	Front	Rear
Shock Type	<input type="checkbox"/> Bladder <input type="checkbox"/> Re Bladder <input type="checkbox"/> Emulsion <input type="checkbox"/> Vented	<input type="checkbox"/> Bladder <input type="checkbox"/> Re Bladder <input type="checkbox"/> Emulsion <input type="checkbox"/> Vented
Shaft Dia	<input type="checkbox"/> 3.5 <input type="checkbox"/> 4.0	<input type="checkbox"/> 3.5 <input type="checkbox"/> 4.0
Piston		
Oil		
Spring		
Stroke		
Droop		

- None
- Composite
- Carbon

- Composite
- Aluminum

- None
- Carbon
- Aluminum

- Aluminum
- Carbon

- None
- Composite
- Carbon

- Composite
- Aluminum

- Composite
- Aluminum

- 20g
- 40g

- Screw
- No Screw

- 1
- 2
- 3

- 1
- 2
- 3

